



## BUILT-IN BOXES

### BUILT-IN BOXES FOR EXTERNAL BLINDS

Built-in boxes for external blinds have become a major trend in recent years. Helps keep the architectural design of the house as clean as possible. This technical solution must be considered before construction or reconstruction.

Everything is customised and carries a 4-year warranty.

# PURENIT BUILT-IN BOX



High compression load (up to 7 tonnes).



Minimum absorption.



Does not burn, melt or drip.



Easy processing.



Excellent insulation properties.



Environmentally friendly.

## Built-in boxes

They are installed before or during the installation of the insulation on the house and their use is highly variable. Even here, however, there are certain limitations and the specific technical design must be discussed with a qualified and trained installation firm in time.

The boxes are made of PURENIT® 550MD, a special construction material. In essence, it is a polyurethane-based material made of hard, recyclable PIR foam with the properties of wood. This lightweight yet rigid board with a thickness of 15 mm is health-safe and

shows high surface and point resistance to mechanical stress. It has a long-term thermal resistance of +100°C, a short-term thermal resistance of +250°C, and minimum absorption properties. It boasts high dimensional stability in a wide range of humidity and temperature conditions.

The use of PURENIT® 550MD prevents the occurrence of thermal bridges. All these properties make this material highly useful mainly in the construction industry. The boxes made of this material are lightweight yet very strong.

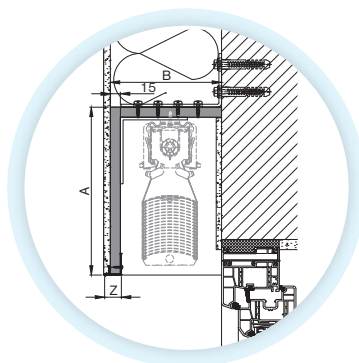

PSL

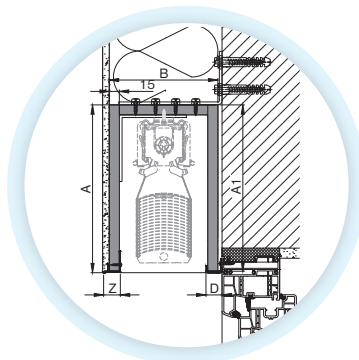

PSU

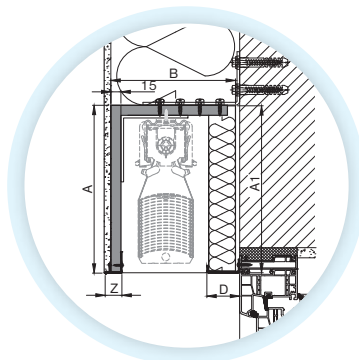

PSI with insulation  
(20, 30, 40, 50, 60 mm)



Legend: A - front height of box, A1 - back height of box, B - box depth, D - mounting profile (U- or Z-option), Z - staff profile (F, L, or UO-option).

Insulation thickness	mm	20	40	60
Thermal resistance R	(m <sup>2</sup> -K)/W	0.714	1.429	2.143
Heat transfer coefficient U**	W/(m <sup>2</sup> -K)	1.171	0.638	0.438
Diffusion resistance S <sub>d</sub> *	m	0.8 - 4	1.6 - 8	2.4 - 12
Thermal conductivity λ <sub>0</sub>	W/(m.K)	0.028	0.028	0.028

Note: As a standard, the installation and front profiles are supplied in the same colour as the selected slat colour.

## Box joining options and angle design

Built-in boxes are supplied in lengths from 45 to 2,000 cm. If the required length of the box is greater than 244 cm, more units are supplied and need to be joined together.

BUILT-IN BOX	C - Box length in whole (cm)		A - front height of box (cm) A1 - back height of box (cm)	B - Box depth (cm)
	Min	Max.	Max.	Max.
	45	244	55	30

## Angle joint

Angle joints are a very popular design of the built-in boxes for houses with corner windows.

### Corner connection - outer corner

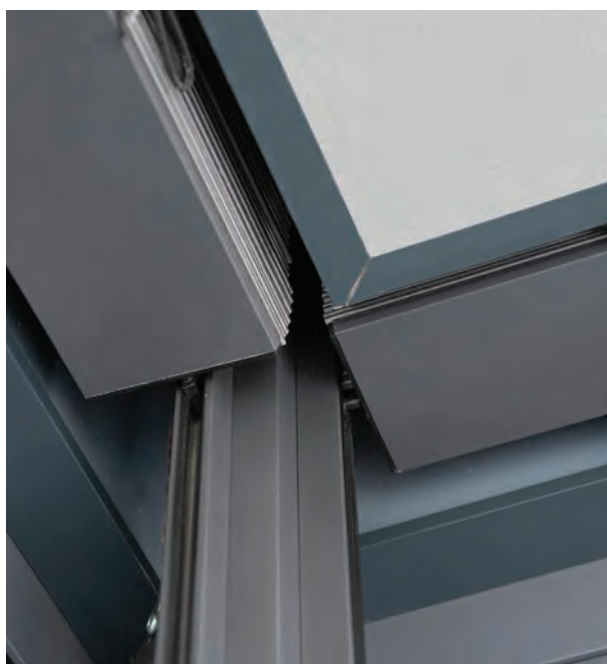
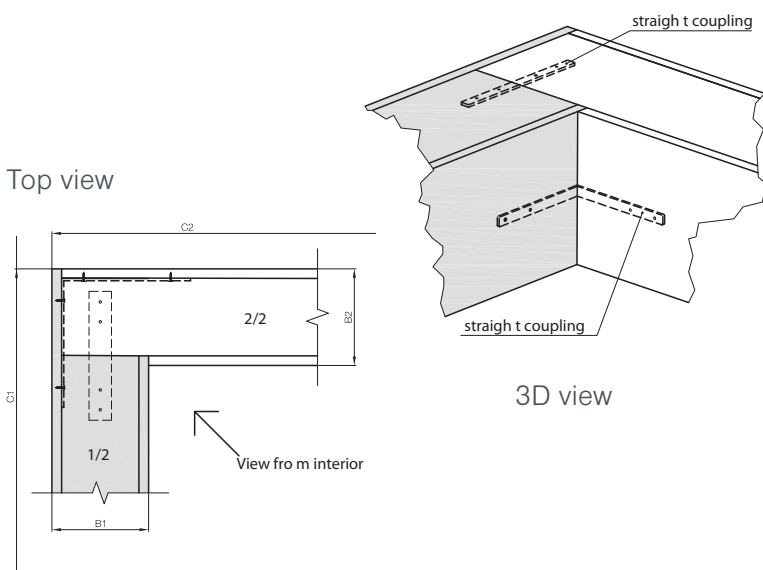

### Inside angle joint

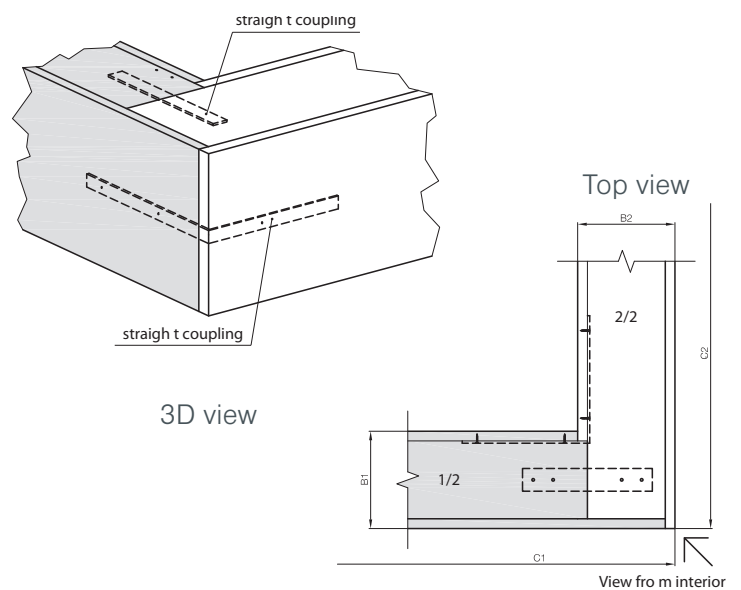

Legend: 1 - 2 - box  
B1, B2 - box depth brutto  
C, C1, C2 - box length

Notice: Boxes are defined from left to right when viewed from the interior.

## Embedded guide rails

This method of installing guide rails can be used if the facade surface is planned to be relatively smooth – plaster, wood cladding, smooth ceramic tiles. It cannot be used where the surface is rough, e.g. with stone cladding. The guide rail is embedded in the façade and does not interfere with the design of the windows. Before finishing the façade, the U-shaped aluminium housing for the guide rail needs to be installed and then plastered in place.

The housing can be cut into the insulation or insulation panels can be glued to the lining with the guide rail housing already in place. The insulation panels are made of Styrodur with or without a Purenit back plate (IP1 or IP2). When installing the blinds, the embedded guide rail itself is inserted into the aluminium housing.

VL7 with an embedded housing

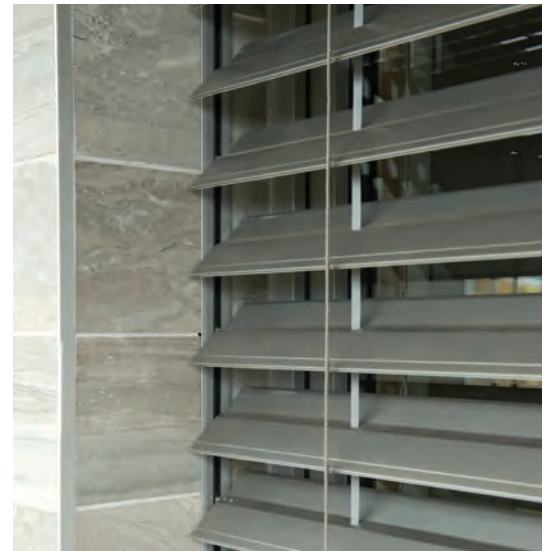
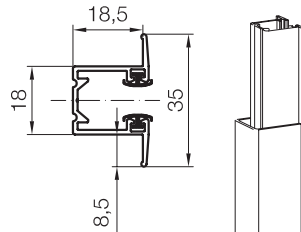

## Partially embedded guide rails

A guide rail 40 mm wide is used where the lining is made of rough surfaces, typically with stone cladding. It combines the natural look of the stone façade with the technical design of the external blinds in an aesthetically pleasing way. Its advantage over protruding rails is in that there is no light between the rail and the stone cladding. The installation must take place in cooperation with the cladding installers to prevent the individual parts of the stone cladding from interfering with the space of the blind and limiting the functionality of the blind.



## Non-embedded guide rails

Non-embedded guide rails are anchored to the lining or to the window frame using aluminium brackets. It is a simple installation method that can be done even after completing the façade.



## Insulation panels

These panels both perform an insulating function and make the installation of the guide rails in the lining much easier. When installing the blinds, only the guide rail itself is inserted in the aluminium housing. This method of installation can be used wherever there is a relatively smooth plaster facade surface planned.

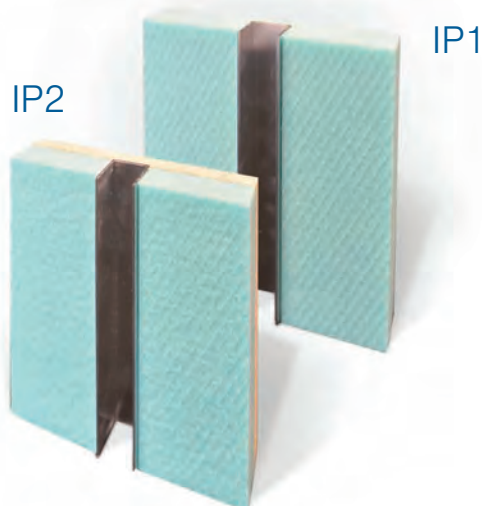

The maximum length of one panel is 240 cm. The insulation is divided by 120 cm; the embedded housing is supplied in one piece.

### Insulation panel types

- IP1 panel of Styrodur 30 mm thick
- IP2 panel consisting of a Purenit panel 10 mm thick and Styrodur panel 20 mm thick

## What does this solution look like?



External blinds are installed in a box concealed under the façade of the house, which completely conceals the rolled-up slats when the blinds are pulled up, hiding and protecting the blinds from environmental influences. The built-in boxes are always made to measure and their dimensions are based on the size of the window or door and the selected type of external blind slats.

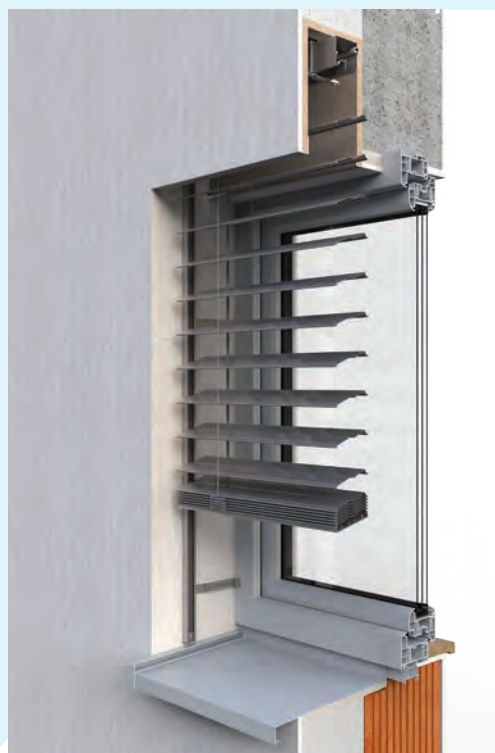

The lower side of the face of the box is provided with an aluminium plaster moulding for a clean finish. The interior of the boxes is painted grey. Available with or without optional back insulation, and it is possible to freely connect them with a straight or corner connection.



For more information go to [www.servisclimax.eu](http://www.servisclimax.eu)

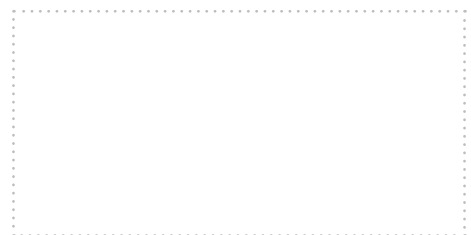

Your CLIMAX partner:

The data given in this material is purely informative. For more details on design options of this product and other products of SERVIS CLIMAX a.s., please contact our nearest business partner. You will find the complete offer, including technical support, on the website [www.servisclimax.eu](http://www.servisclimax.eu)